



Instructions for making a mask

Using a sewing machine

Materials

- Two 255 mm by 150 mm rectangles of cotton fabric
- Two 150 mm pieces of elastic (or rubber bands, string, cloth strips, hair ties)
- Needle and thread (safety pins or a stapler will also work)
- Scissors
- Sewing machine (if available)

Instructions

Step 1. Cut out two 255 mm by 150 mm rectangles of cotton fabric. Use tightly woven cotton, such as quilting fabric or cotton sheets. T-shirt fabric will work too. Stack the 2 rectangles, as you will sew the face covering as if it was a single piece of fabric.

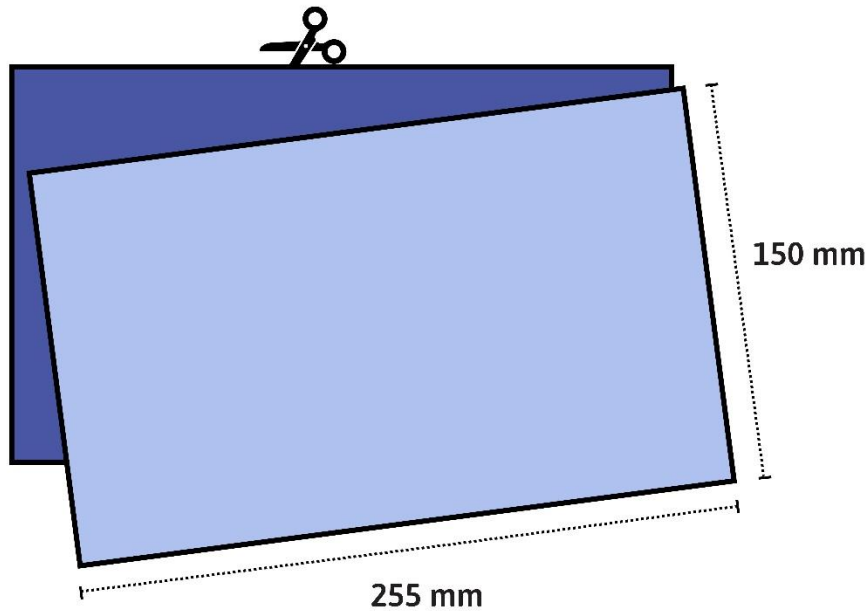

Step 2. Fold over the long sides 6 mm hem. Then fold the double layer of fabric over 12 mm along the short sides and stitch down.

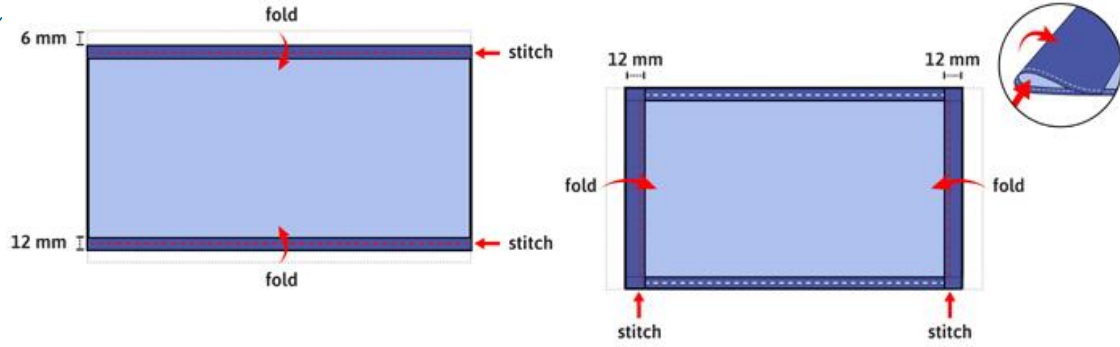

Step 3. Run a 150 mm length of 3 mm wide elastic through the wider hem on each side of the face covering. These will be the ear loops. Use a large needle or a bobby pin to thread it through. Tie the ends tight.

Use hair ties or elastic headbands if you do not have elastic. If you only have string, you can make the ties longer and tie the face covering behind your head.

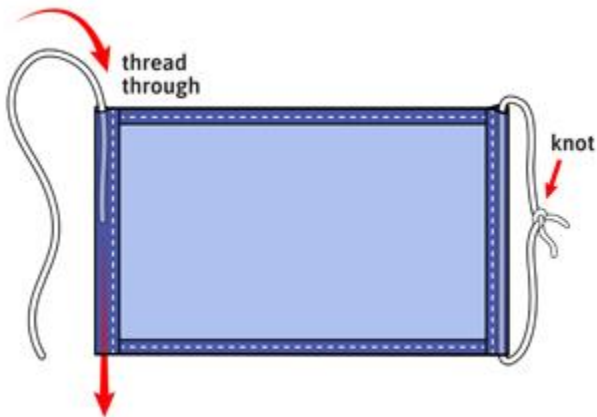

Step 4. Gently pull on the elastic so that the knots are tucked inside the hem. Gather the sides of the face covering on the elastic and adjust so it fits your face. Then securely stitch the elastic in place to keep it from slipping.

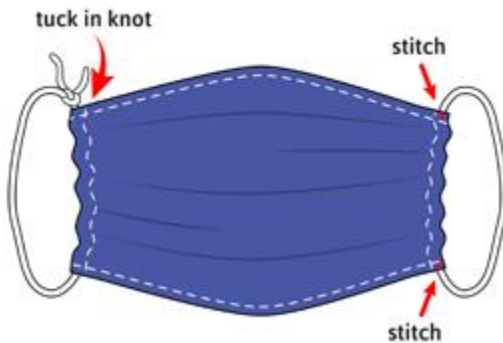

Without a sewing machine

Materials

- Bandana (or square cotton cloth approximately 510 mm by 510 mm)
- Coffee filter or a folded paper towel
- Rubber bands (or hair ties)
- Scissors (if you are cutting your own cloth)

Instructions

Step 1. Cut a coffee filter horizontally across the middle. Keep the top with the rounded part.



Step 2. Fold a square bandana in half.

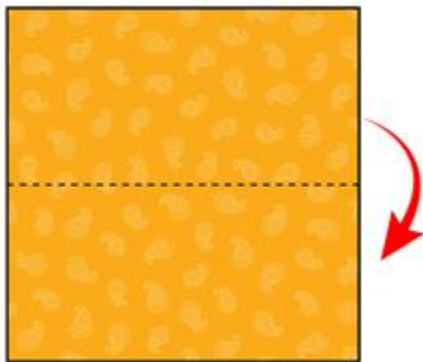

Step 3. Put the rounded top of the cut filter in the center of your folded bandana. Fold the top of the bandana down over the filter. Then fold the bottom of the bandana up over the filter.

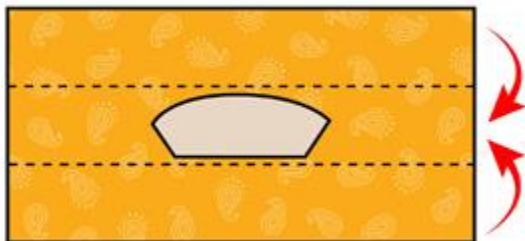

Step 4. Insert the folded cloth into 2 rubber bands or hair ties, about 150 mm apart.



Step 5. Fold sides to the middle and tuck around the bands or hair ties.

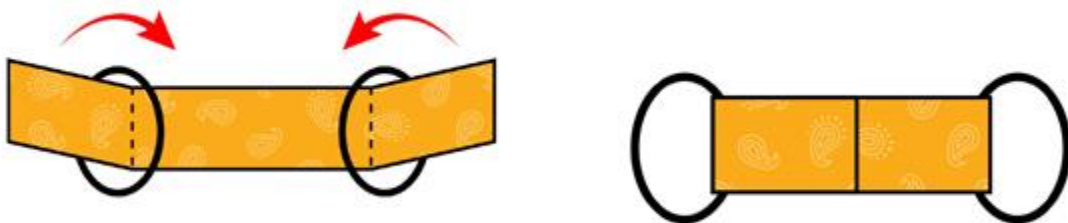

Step 6. Pull the bands or hair ties around your ears.

